

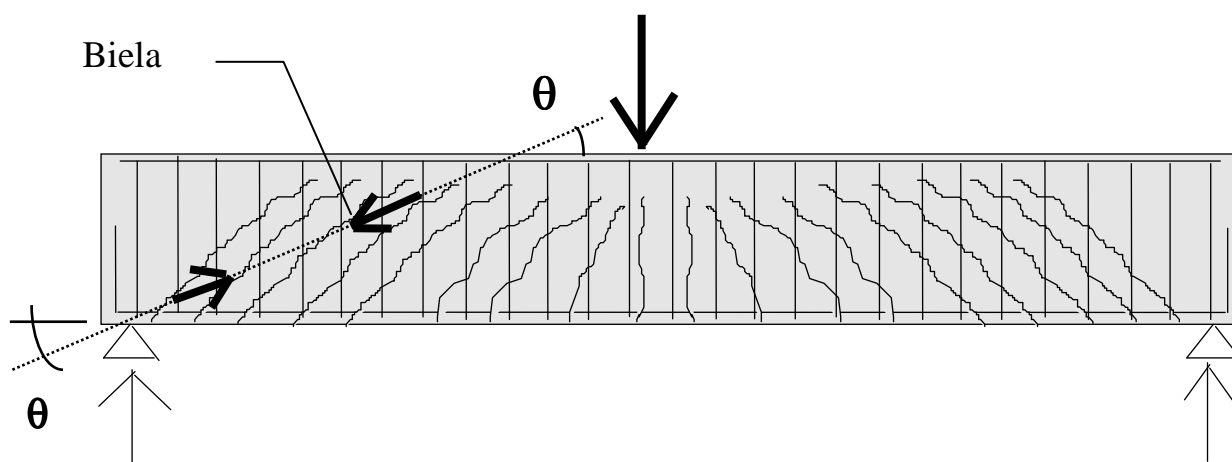

Resistência a força cortante

CEB-FIP Código Modelo 1990

O ângulo da biela pode variar de $\theta = 45^\circ$ a $\theta = 18^\circ$



O ângulo da biela equivalente não coincide com o ângulo da fissura

Devido à existência da tração dos estribos, a resistência a compressão do concreto da biela inclinada diminui.

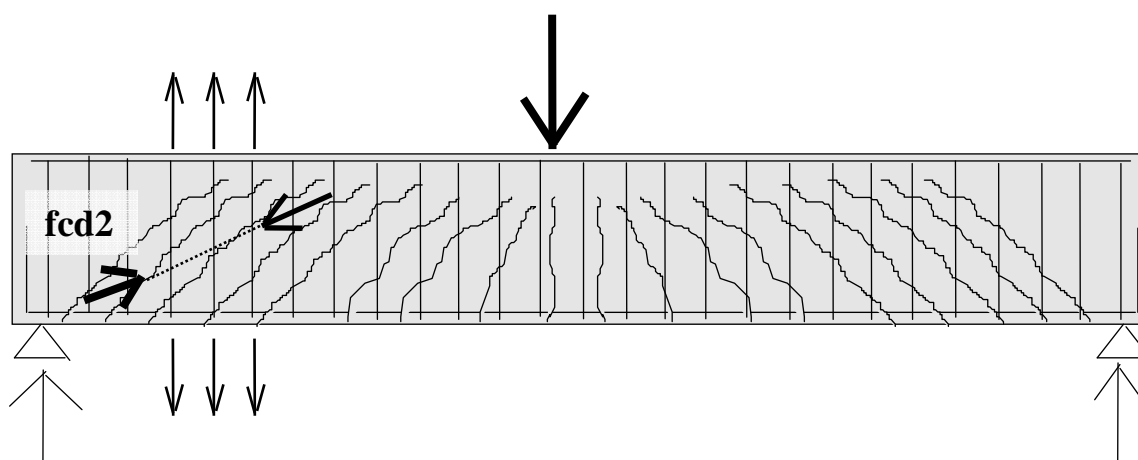

$$f_{cd2} = 0.60 \times [1 - f_{ck}/250] \times f_{cd}$$

Exemplo: $f_{ck} = 25 \text{ MPa} > f_{cd1} = 0.60 \times 0.90 f_{cd} = 0.54 f_{cd}$



Na zona comprimida pela flexão existe uma menor redução da resistência à compressão .

Segundo o CEB-FIP Código Modelo 1990

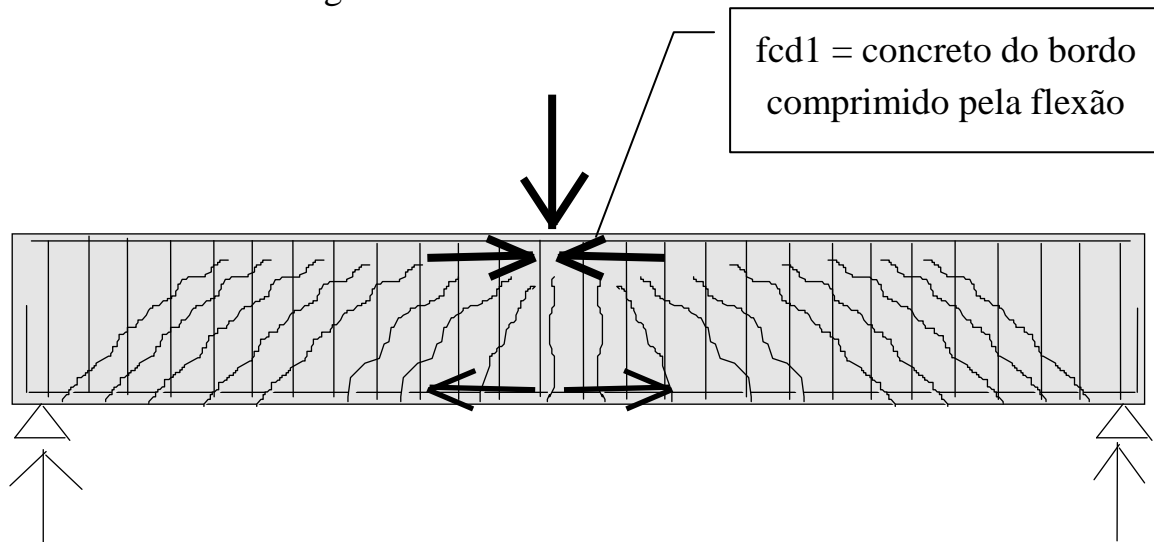

$$f_{cd1} = 0.85 \times [1 - f_{ck}/250] \times f_{cd}$$

Exemplo : $f_{ck} = 25 \text{ MPa} > f_{cd1} = 0.85 \times 0.90 f_{cd} = 0.765 f_{cd}$

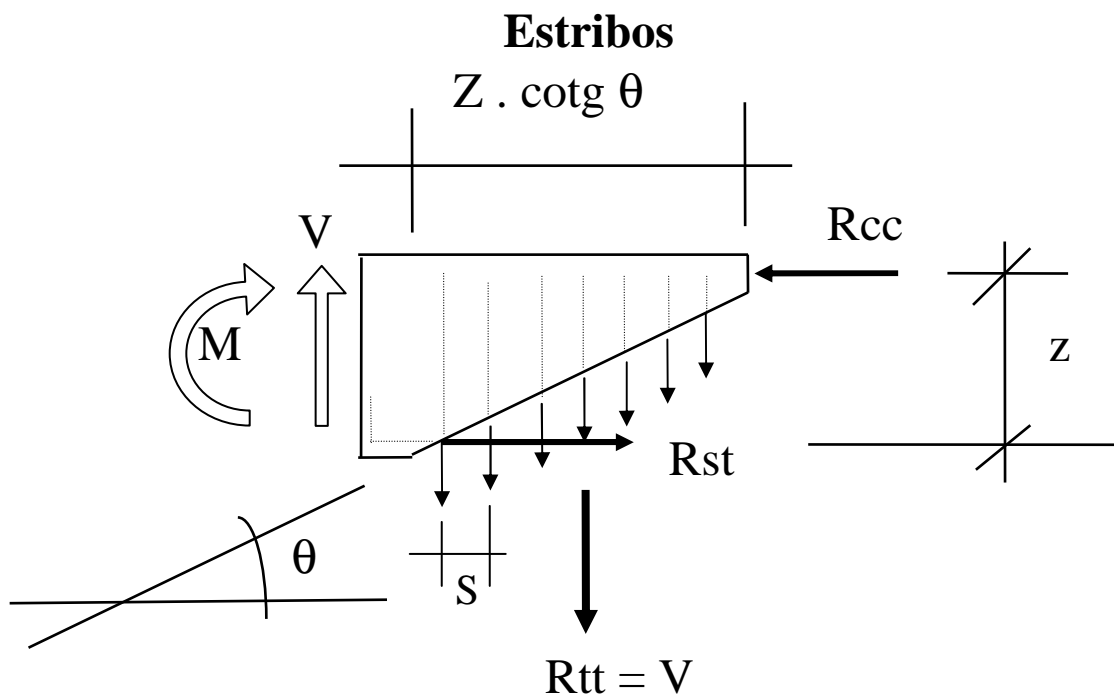

Sendo A_{sw} a área da seção transversal de cada estribo e S o espaçamento entre eles temos : $A_{tt} = (z \cdot \cotg \theta / S) A_{sw}$



A tensão nos estribos será : $\sigma_{tt} = R_{tt} / A_{tt} = V \cdot S / A_{sw} \cdot z \cdot \cotg\theta$

$$\sigma_{estribo} = V \frac{s}{A_{sw} \cdot \cotg\theta} \cdot \frac{b}{s \cdot b} = \frac{\frac{V}{b \cdot z}}{\frac{A_{sw}}{b \cdot S} \cdot \cotg\theta} = \frac{\tau}{\rho_w \cdot \cotg\theta}$$

$$\sigma_{estribo} = \frac{\tau}{\rho_w \cdot \cotg\theta}$$

Em conseqüência a quantidade de estribos vale: $\rho_w = \frac{A_{sw}}{b \cdot S} = \frac{\tau_w d}{f_{yd} \cdot \cotg\theta} = \frac{\left(\frac{Vd}{b \times z}\right)}{\left(\frac{f_{yk}}{1,15}\right) \times \cotg\theta}$

Exemplo: Usando $\theta = 45^\circ \dots \cotg\theta = 1.0$

$\theta = 30^\circ \dots \cotg\theta = 1.73$

$\theta = 18^\circ \dots \cotg\theta = 3.0$

Com $\theta = 18^\circ$ preciso de 1/3 dos estribos que preciso para $\theta = 45^\circ$

Geralmente se usa $\theta \geq 30^\circ$

Tensões nas bielas comprimidas diagonais:

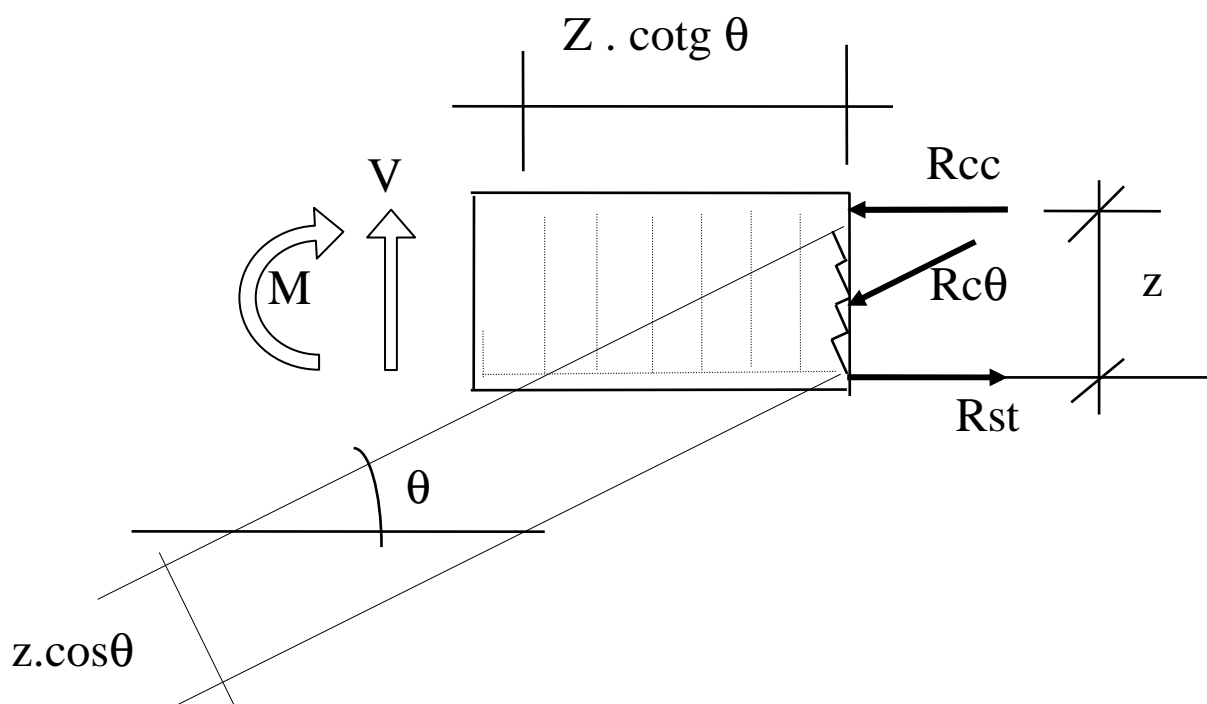



A resultante das tensões de compressão na biela vale :

$$R_{c\theta} = \sigma_{c\theta} \cdot b \cdot (z \cdot \cos \theta); \text{ onde } b = \text{largura da viga}$$

A componente vertical de $R_{c\theta}$ será igual à força cortante .

$$R_{c\theta} \cdot \sin \theta = \sigma_{c\theta} \cdot b \cdot (z \cdot \cos \theta) \cdot \sin \theta = V$$

$$\sigma_{c\theta} = (V / b \cdot z) \cdot (1 / \sin \theta \cdot \cos \theta) = 2 \tau / \sin 2\theta$$

Logo, a tensão nas bielas comprimidas diagonais vale : $\sigma_{c\theta} = \frac{2 \cdot \tau}{\sin 2\theta}$

Exemplo: usando $\theta = 45^\circ \dots \sin 2\theta = 1.0$ logo :

$\sigma_{c\theta} = 2.00 \tau \leq 0.60 [1 - f_{ck} / 250] f_{cd}$ com f_{ck} em MPa	
Exemplo : $f_{ck} = 25\text{MPa}$	$\tau_{wd} < 0.27 f_{cd}$
$f_{ck} = 35\text{MPa}$	$\tau_{wd} < 0.26 f_{cd}$

$\theta = 30^\circ \dots \sin 2\theta = 0.866$ logo $\sigma_{c\theta} = 2.30 \tau$

$\sigma_{c\theta} = 2.30 \tau \leq 0.60 [1 - f_{ck} / 250] f_{cd}$ com f_{ck} em MPa	
Exemplo : $f_{ck} = 25\text{MPa}$	$\tau_{wd} < 0.235 f_{cd}$
$f_{ck} = 35\text{MPa}$	$\tau_{wd} < 0.224 f_{cd}$

$\theta = 18^\circ \dots \sin 2\theta = 0.588$ logo $\sigma_{c\theta} = 3.40 \tau$

$\sigma_{c\theta} = 3.40 \tau \leq 0.60 [1 - f_{ck} / 250] f_{cd}$ com f_{ck} em MPa	
Exemplo : $f_{ck} = 25\text{MPa}$	$\tau_{wd} < 0.16 f_{cd}$
$f_{ck} = 35\text{MPa}$	$\tau_{wd} < 0.15 f_{cd}$

Com $\theta = 18^\circ$ teremos uma tensão na biela :

$$\sigma_{c(\theta=18^\circ)} = 1.70 \sigma_{c(\theta=45^\circ)}$$



Força longitudinal de tração (decalagem) (decalagem)

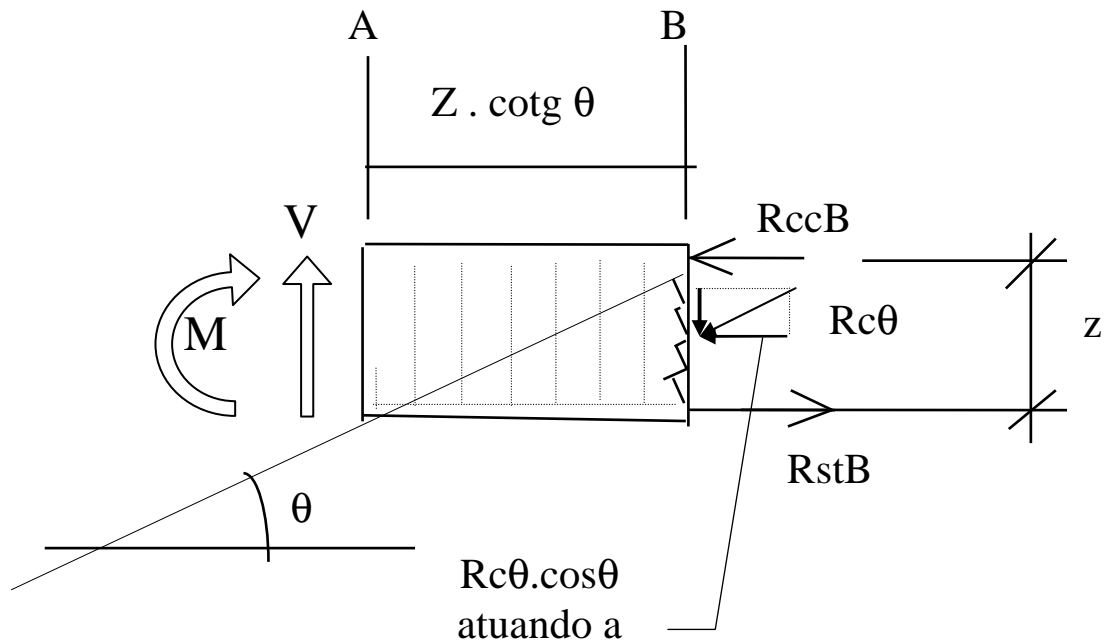

$$M + V \cdot z \cdot \cot\theta + R_{c\theta} \cdot \cos\theta \cdot (z/2) - R_{stB} \cdot z = 0$$

Como $R_{c\theta} \cdot \sin\theta = V$; $R_{c\theta} = V / \sin\theta$

$$(M + V \cdot z \cdot \cot\theta) + [(V / \sin\theta) \cdot \cos\theta] \cdot (z/2) = R_{stB} \cdot z$$

$$M_{,B} + [V \cdot (z/2) \cdot \cot\theta] = R_{stB} \cdot z$$

$$R_{st,B} = \frac{1}{z} \left[M_{,B} + V \cdot \frac{z}{2} \cdot \cot\theta \right]$$

Em resumo : A decalagem será a metade da projeção horizontal da biela.

$$al = \frac{z}{2} \cdot \cot\theta$$



$$\text{Para } \theta = 90^\circ \quad al = 0$$

Isto ocorre no ponto de momento máximo onde a fissura é perpendicular ao eixo da viga.

$$\text{Para } \theta = 45^\circ \quad al = 0,500.z$$

$$\text{Para } \theta = 30^\circ \quad al = 0,866.z$$

$$\text{Para } \theta = 18^\circ \quad al = 1,538.z$$

Em geral , com estribos a 90° , a força de tração na armadura de flexão será :

$$R_{st} = \frac{M}{z} + \frac{V}{2} \cdot \cot \theta$$

$$\text{Para } \theta = 90^\circ \quad R_{st} = \frac{M}{z}$$

$$\text{Para } \theta = 45^\circ \quad R_{st} = \frac{M}{z} + 0,500.V$$

$$\text{Para } \theta = 30^\circ \quad R_{st} = \frac{M}{z} + 0,866.V$$

$$\text{Para } \theta = 18^\circ \quad R_{st} = \frac{M}{z} + 1,538.V$$



Cabos de protensão

Caso existam cabos de protensão a meia altura na alma da viga é necessário introduzir as forças de protensão nas equações de equilíbrio .

Isso acarreta formulações mais elaboradas .

Programas de computador são usados para resolver essas equações.

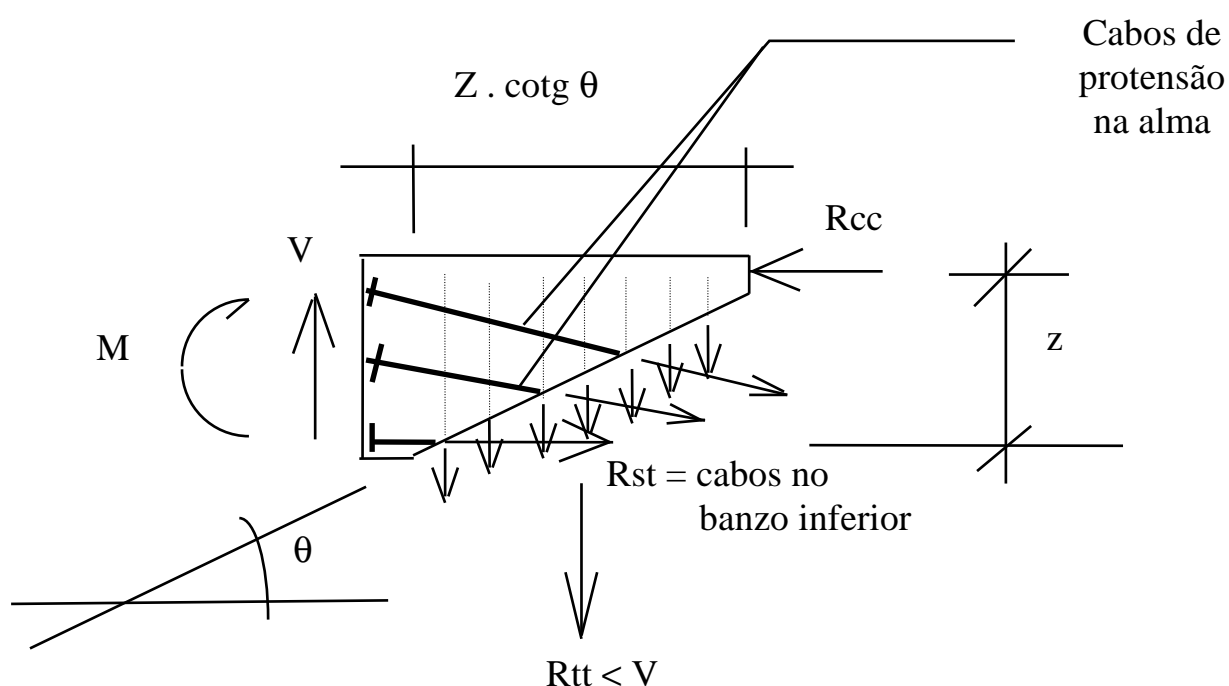

É um hábito calcular apenas o efeito da componente transversal da força do cabo , descontando essa componente da força cortante atuante .

É preciso no entanto considerar também o efeito das forças do cabo na equação de equilíbrio de momentos e na equação de equilíbrio longitudinal.

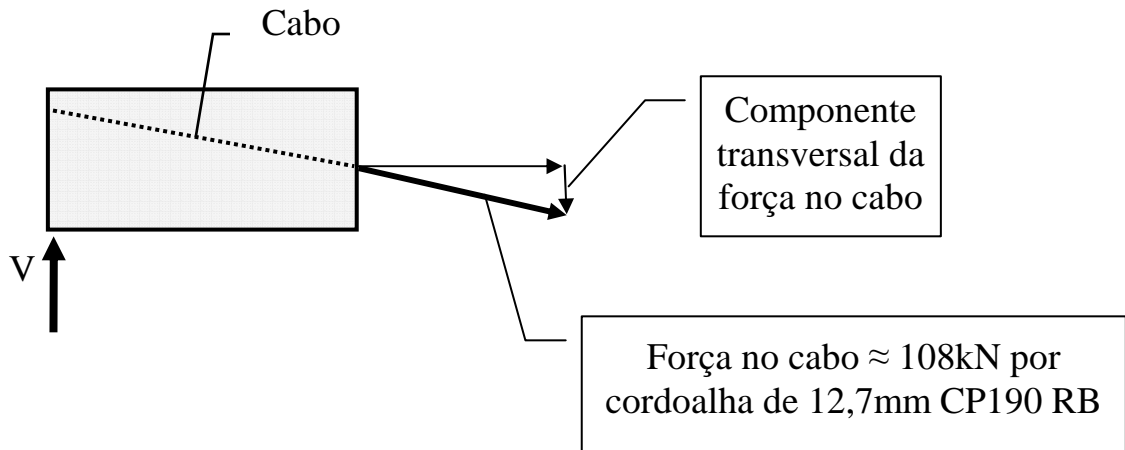

Exemplo : Viga protendida

Uso do programa Sheardes :

Dados :

$$V_d = 1,35 V_g + 1,50 V_p = 1400 \text{ kN}$$

$$M_d = 1,35 M_g + 1,50 M_p = 5000 \text{ kN.m}$$

$$f_{ck} = 30 \text{ MPa}$$

$$\text{Estribo} = \text{CA50} , f_{yk} = 500 \text{ MPa}$$

$$\text{Cabos} = 12 \text{ cordoalhas } 12,7\text{mm} , \text{CP } 190 \text{ RB } f_{yk} = 1700 \text{ MPa}$$

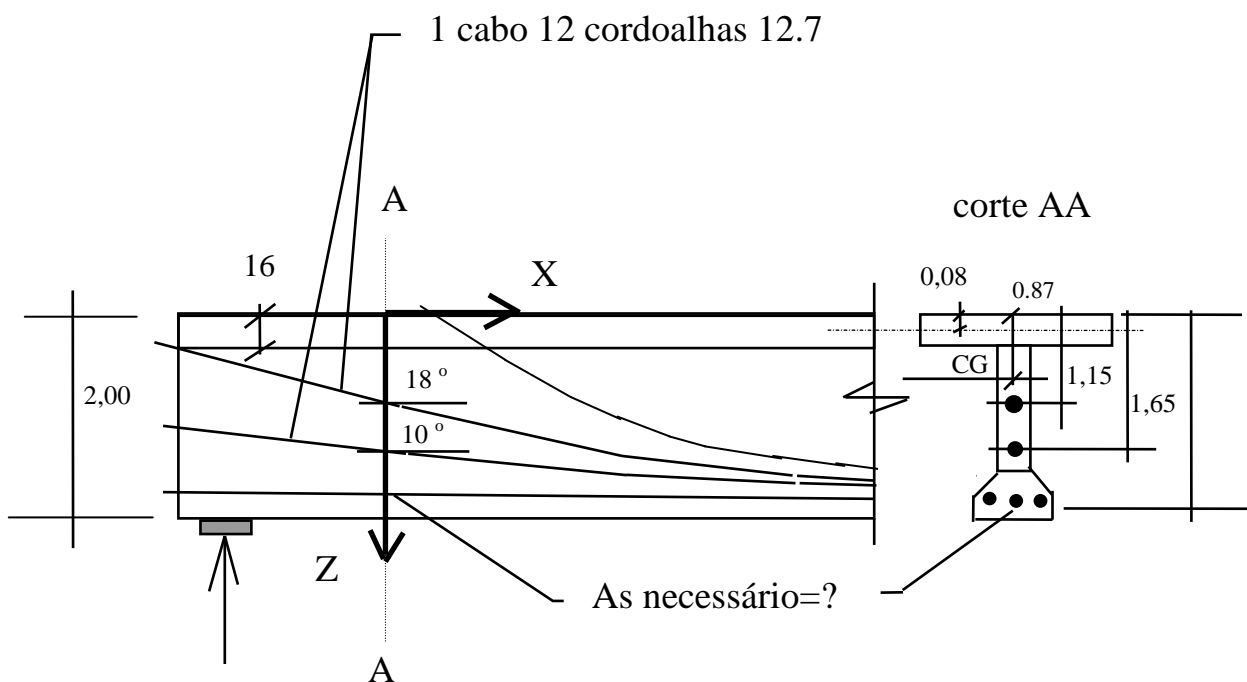



Convenção de sinais

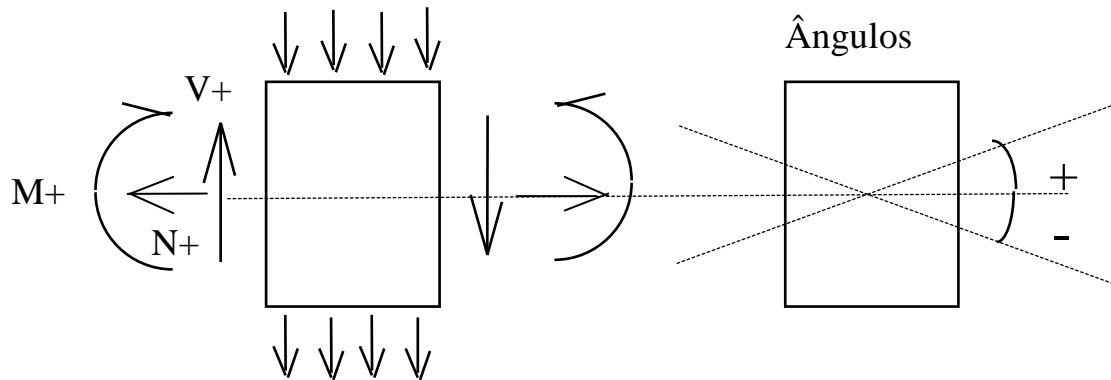

Program Sheardes for shear design of beams according to the CEB-90 MC
This program determines the compression force, the tensile force, the concrete web thickness and the amount of steel stirrups for flanged beams subjected to Axial force, Bending moment and Shear force.

This program was prepared by B. Ernani Diaz of the Engineering School of the Federal University of Rio de Janeiro.

Cálculos iniciais:

$$f_{cd} = 30000 / 1.50 = 20000 \text{ kN/m}^2$$

$$f_{cd1} / f_{cd} = 0.85 [1 - 30 / 250] = 0.748$$

$$f_{yd} = 1700000 / 1.15 = 1478260 \text{ kN/m}^2 \text{ CP 190RB}$$

$$f_{cwd} = f_{cd} = 20000 \text{ kN/m}^2$$

$$f_{cd2} = 0.60 [1 - 30 / 250] = 0.528$$

$$f_{ywd} = 500000 / 1.15 = 434782 \text{ kN/m}^2$$



INPUT (arquivo cortante.dat)

Project Designation

IME 2007 fck=30MPa CP-190RB

Design stresses of the beam elements(item 6.2.2.2)

Flange_Concr,	fcd1/fcd,	Flange_Steel,	Web_Concr,	fcd2/fcwd,	Stirr_Steel
fcd	fcd1/fcd	fyd	fcwd	fcd2/fcwd	fywd
20000.0	0.7480	1478260.0	20000.0	0.5280	434782.0

Designation of the section

Secao AA

Z coordinates for the location of the flanges and beam axis

Upper_Fl.	Lower_Fl.	Beam_Axis
0.080	1.900	0.870

Angles [degrees] of the Upper Flange and Lower Flange

Upper_Flange	Lower_Flange
0.00	0.00

Angles in degrees of the concrete struts and stirrups in the web

Concrete_Struts	Steel_Stirrups
<u>45.00</u>	90.00

Number of Prestressing Cables in the Web

2

Cable Design Force(items 1.4.3.2,1.6.2.4), Z-coordinate and Angle

Cable_Force(positive value)	Z_Coord.	Angle[degree]
1296.00	1.15	-18.00
1296.00	1.65	-10.00

Number of loadings

1

Loading Designation

carga total

Design Internal Forces (multiplied by safety factors)

Axial_Force	Shear_Force	Bend_Moment	Addit_Upper_Force	Addit_Lower_Force
Nd	Vd	Md	design value	design value
0.00	1400.00	5000.00	0.00	0.00

Design Distributed Forces (multiplied by safety factors)

Up_Dist_Force	Lo_Dist_Force
0.00	0.00



OUTPUT (arquivo cortante .out)

carga total - BIELA a 45 graus

Computed Forces and Design

Upper flange

Force	Necess. Area	Material	
-3043.26	<u>0.203427</u>	<u>concrete</u>	Comentário : 0.20m ² = 0.16 m x 1.25m

Lower flange

Force	Necess. Area	Material	
1308.85	<u>0.000885</u>	<u>steel</u>	Comentário : 1 cabo 12 cordoalhas = = 12 cm ² > 8.85 cm ²

Distributed forces in the web [force/length] and Design

Z_Coord	Strut_Forc	Stirr_Forc	Long_Forc	Shear_Forc	Web_Thickn	Steel_As/s
<u>0.080</u>	-851.06	425.53	-425.53	425.53	<u>0.08</u>	<u>0.000979</u>
<u>0.990</u>	-851.06	425.53	-425.53	425.53	<u>0.08</u>	<u>0.000979</u>
<u>1.900</u>	-851.06	425.53	-425.53	425.53	<u>0.08</u>	<u>0.000979</u>

Comentário : Espessura da alma = 8cm + ϕ bainha = 8 + 7 = 15cm

Armadura estribo = 9.79 cm² / m

ϕ 10mm cada 15cm = 10.67 cm² / m

INPUT arquivo cortan18.dat

```
IME 2007 fck=30MPa CP-190RB
20000 0.748 1478260 20000 0.528 434782
Secao AA
0.08 1.90 0.87
0 0
18 90
2
1296 1.15 -18
1296 1.65 -10
1
carga total
0 1400 5000 0 0
0 0
```



Project Designation

IME 2007 fck=30MPa CP-190RB

Design stresses of the beam elements(item 6.2.2.2)

Flange_Concr,	fcd1/fcd,	Flange_Steel,	Web_Concr,	fcd2/fcwd,	Stirr_Steel
fcd	fcd1/fcd	fyd	fcwd	fcd2/fcwd	fywd
20000.0	0.7480	1478260.0	20000.0	0.5280	434782.0

Designation of the section

Secao AA

Z coordinates for the location of the flanges and beam axis

Upper_Fl.	Lower_Fl.	Beam_Axis
0.080	1.900	0.870

Angles [degrees] of the Upper Flange and Lower Flange

Upper_Flange	Lower_Flange
0.00	0.00

Angles in degrees of the concrete struts and stirrups in the web

Concrete_Struts	Steel_Stirrups
18.00	90.00

Number of Prestressing Cables in the Web

2

Cable Design Force(items 1.4.3.2,1.6.2.4), Z-coordinate and Angle

Cable_Force(positive value)	Z_Coord.	Angle[degree]
1296.00	1.15	-18.00
1296.00	1.65	-10.00

Number of loadings

1

Loading Designation

carga total

Design Internal Forces (multiplied by safety factors)

Axial_Force	Shear_Force	Bend_Moment	Addit_Upper_Force	Addit_Lower_Force
Nd	Vd	Md	design value	design value
0.00	1400.00	5000.00	0.00	0.00

Design Distributed Forces (multiplied by safety factors)

Up_Dist_Force	Lo_Dist_Force
0.00	0.00



carga total - BIELA a 18 graus

Computed Forces and Design

Upper flange Force Necess. Area Material

-2238.72 0.149647 concrete

Comentário : 0.15m² = 0.16 m x 0.95m

Lower flange Force Necess. Area Material

1308.85 0.001430 steel

Comentário : 1 cabo 16 cordoalhas = 16 cm² > 14.3 cm²

Distributed forces in the web [force/length] and Design

Z_Coord Strut_Forc Stirr_Forc Long_Forc Shear_Forc Web_Thickn Steel_As/s

0.080 -1447.91 138.26 -1309.65 425.53 0.14 0.000318

0.990 -1447.91 138.26 -1309.65 425.53 0.14 0.000318

1.900 -1447.91 138.26 -1309.65 425.53 0.14 0.000318

Comentário : Espessura da alma = 14cm + ϕ bainha = 14 + 7 = 21cm

Armadura estribo necessária = 3.18 cm² / m

Usar : ϕ 6.3mm cada 15cm = 4.15 cm² / m

Envoltória para trem tipo ferroviário **COOPER 80** isto é 1800 kN AREA

Envoltória de Esforços Internos nos Membros- Valores mínimos

Solicitação de **Esforço Cortante**

Membro	Extr_Inicial			Extr_Final		
	Forc_x	Forc_z	Mom_y	Forc_x	Forc_z	Mom_y
ATENCAO AOS VALORES CONCOMITANTES						
1	0	0*	0	0	-70.47*	1877.3
2	0	-70.47*	1877.3	0	-232.71*	5510.6
3	0	-232.71*	5510.6	0	-444.93*	9219
4	0	-444.93*	9219	0	-683.15*	12133
5	0	-683.15*	12133	0	-979.77*	14983
6	0	-979.77*	14983	0	-1354*	16152
7	0	-1354*	16152	0	-1806.9*	16046
8	0	-1806.9*	16046	0	-2341*	13859
9	0	-2341*	13859	0	-2911*	8616.6
10	0	-2911*	8616.6	0	-3472*	-0.004401



Envoltória para ferroviário **COOPER 80** isto é 1800 kN AREA
Envoltória de Esforços Internos nos Membros- Valores máximos
Solicitação de **Esforço Cortante**

Membro	Extr_Inicial			Extr_Final		
	Forc_x	Forc_z	Mom_y	Forc_x	Forc_z	Mom_y
ATENCAO AOS VALORES CONCOMITANTES						
1	0	3573.7*	-0.0045304	0	2933.5*	8683.2
2	0	2933.5*	8683.2	0	2350*	13934
3	0	2350*	13934	0	1843.8*	16598
4	0	1843.8*	16598	0	1405.4*	16639
5	0	1405.4*	16639	0	1037*	15348
6	0	1037*	15348	0	712.01*	12645
7	0	712.01*	12645	0	438.76*	9091.1
8	0	438.76*	9091.1	0	237.26*	5677.5
9	0	237.26*	5677.5	0	68.469*	1883.1
10	0	68.469*	1883.1	0	0*	0

Envoltória para ferroviário **COOPER 80** isto eh 1800 kN AREA

Envoltória de Esforços Internos nos Membros- Valores mínimos
Solicitação de **Momento Fletor**

Membro	Extr_Inicial			Extr_Final		
	Forc_x	Forc_z	Mom_y	Forc_x	Forc_z	Mom_y
ATENCAO AOS VALORES CONCOMITANTES						
1	0	3170.3	-0.0046673*	0	0	0*
2	0	0	0*	0	0	0*
3	0	0	0*	0	0	0*
4	0	0	0*	0	0	0*
5	0	0	0*	0	0	0*
6	0	0	0*	0	0	0*
7	0	0	0*	0	0	0*
8	0	0	0*	0	0	0*
9	0	0	0*	0	0	0*
10	0	0	0*	0	-3084.8	-0.0046528*



envoltoria para ferroviario **COOPER 80** isto eh 1800 kN AREA

Envoltoria de Esforços Internos nos Membros- Valores máximos

Solicitacao de **Momento Fletor**

Membro	Extr_Inicial			Extr_Final		
	Forc_x	Forc_z	Mom_y	Forc_x	Forc_z	Mom_y
ATENCAO AOS VALORES CONCOMITANTES						
1	0	0	0*	0	2781.9	8962.2*
2	0	2781.9	8962.2*	0	1957.6	15494*
3	0	1957.6	15494*	0	1180.9	19728*
4	0	1180.9	19728*	0	454.98	21928*
5	0	454.98	21928*	0	377.03	22844*
6	0	377.03	22844*	0	-227.35	22341*
7	0	-227.35	22341*	0	-1060.1	19866*
8	0	-1060.1	19866*	0	-1653.9	15386*
9	0	-1653.9	15386*	0	-2701.1	8771.4*
10	0	-2701.1	8771.4*	0	0	0*

Programa SHEARDES

Designação do Trem Tipo

Envoltória para Trem Tipo Ferroviario tipo TB36 ABNT 4x36ton isto é 1440 kN

Envoltoria de Esforços Internos nos Membros- **Valores máximos**

Solicitacao de **Momento Fletor**

Membro	Extremidade_Inicial			Extremidade_Final		
	$\phi \times \text{Forc}_X$	$\phi \times \text{Forc}_z$	$\phi \times \text{Mom}_Y$	$\phi \times \text{Forc}_x$	$\phi \times \text{Forc}_z$	$\phi \times \text{Mom}_y$
ATENCAO AOS VALORES CONCOMITANTES						
1	0	0	0*	0	2571.1	7931.9*
2	0	2571.1	7931.9*	0	1577.6	13990*
3	0	1577.6	13990*	0	1358.5	18335*
4	0	1358.5	18335*	0	365.06	20968*
5	0	365.06	20968*	0	-299.87	21808*
6	0	-299.87	21808*	0	-365.06	20968*
7	0	-365.06	20968*	0	-1358.5	18335*
8	0	-1358.5	18335*	0	-1577.6	13989*
9	0	-1577.6	13989*	0	-2571.1	7931.9*
10	0	-2571.1	7931.9*	0	0	0*



Exemplo : Ponte Ferroviária da empresa Engefer

Projeto : Eng. Fernando Uchoa Cavalcanti

Publicação : Revista ESTRUTURA 93 – Dezembro 1980

Cálculo estrutural feito em sala de aula, no IME como exercício da cadeira de concreto protendido.(2007)

Observação : Para não alongar os cálculos, faremos a verificação apenas na seção do apoio. Em um projeto completo, com viga simétrica, toda a verificação deve ser feita, em pelo menos 5 seções transversais.

Seção S4

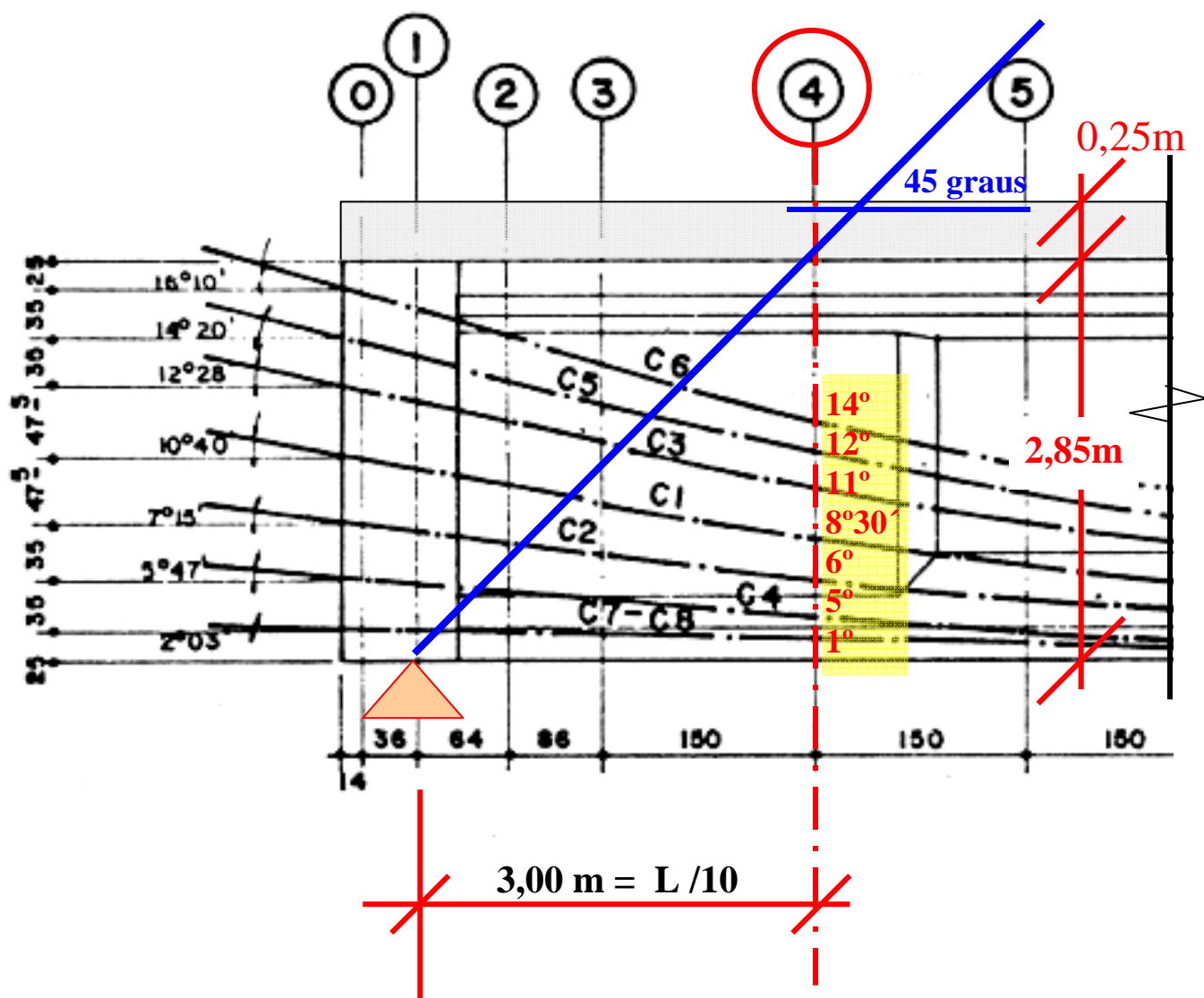



4

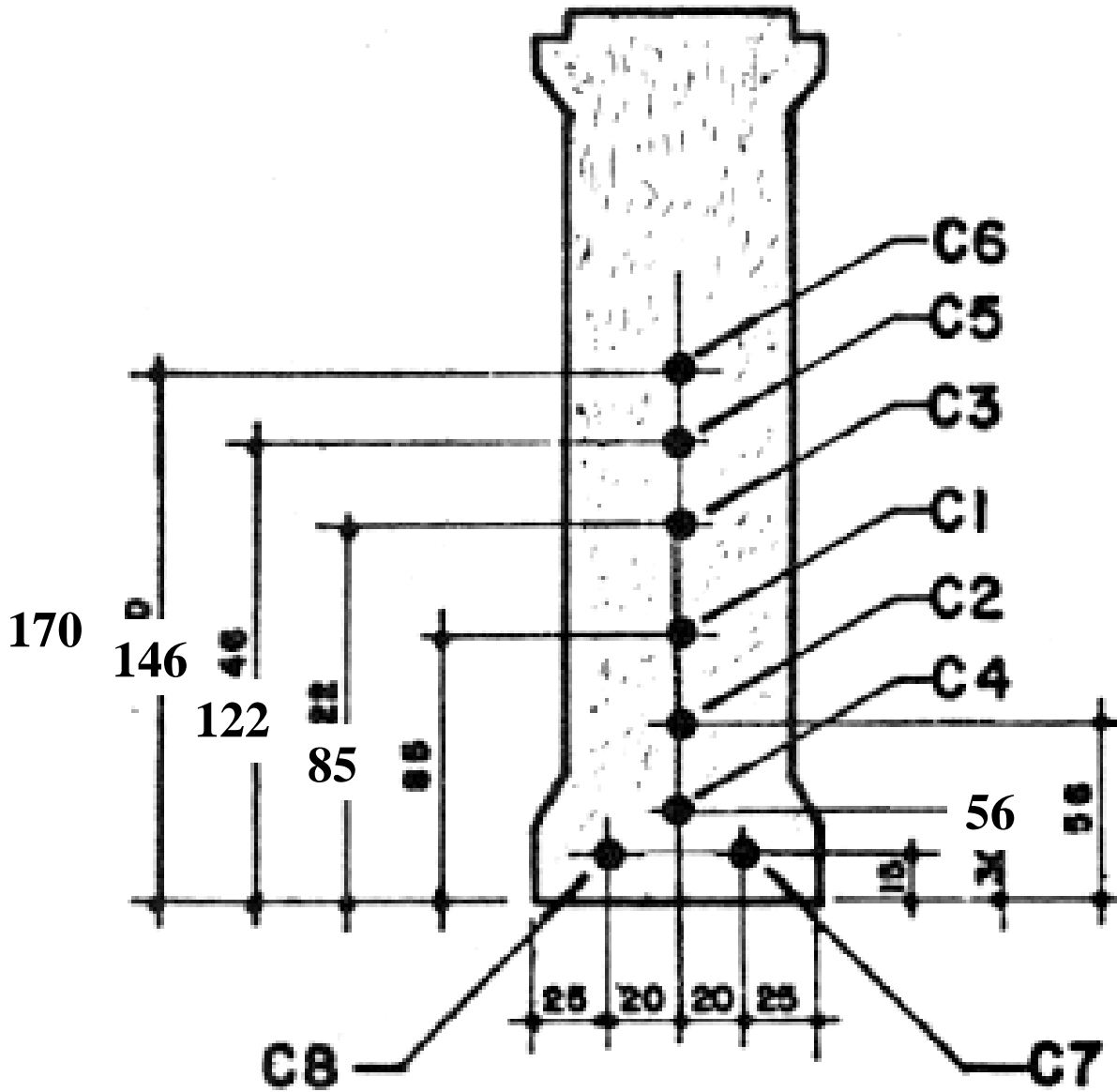



Cabo	Força estimada no cabo F_{cabo} (kN)	Z topo (m)	A (graus)	$F_{cabo} \times \sin \alpha$ (kN)	$F_{cabo} \times \cos \alpha$ (kN)	$(F_{cabo} \times \cos \alpha) \times (z_{topo} - 0,125m)$ (kN.m)
C6	1140	1,40	-14	275,8	1106,1	1410,3
C5	1140	1,64	-12	237,0	1115,1	1689,3
C3	1140	1,88	-11	217,5	1119,0	1963,8
C1	1140	2,25	-8	158,7	1128,9	2398,9
C2	1140	2,54	-6	119,2	1133,7	2737,9
C4	1140	2,80	-5	99,3	1135,7	3038,0
				$\Sigma = 1107,5$ kN		$\Sigma = 13238,2$ kN.m
C7 e C8	A determinar	2,95	-1			



Peso Próprio da Viga Pré-moldada

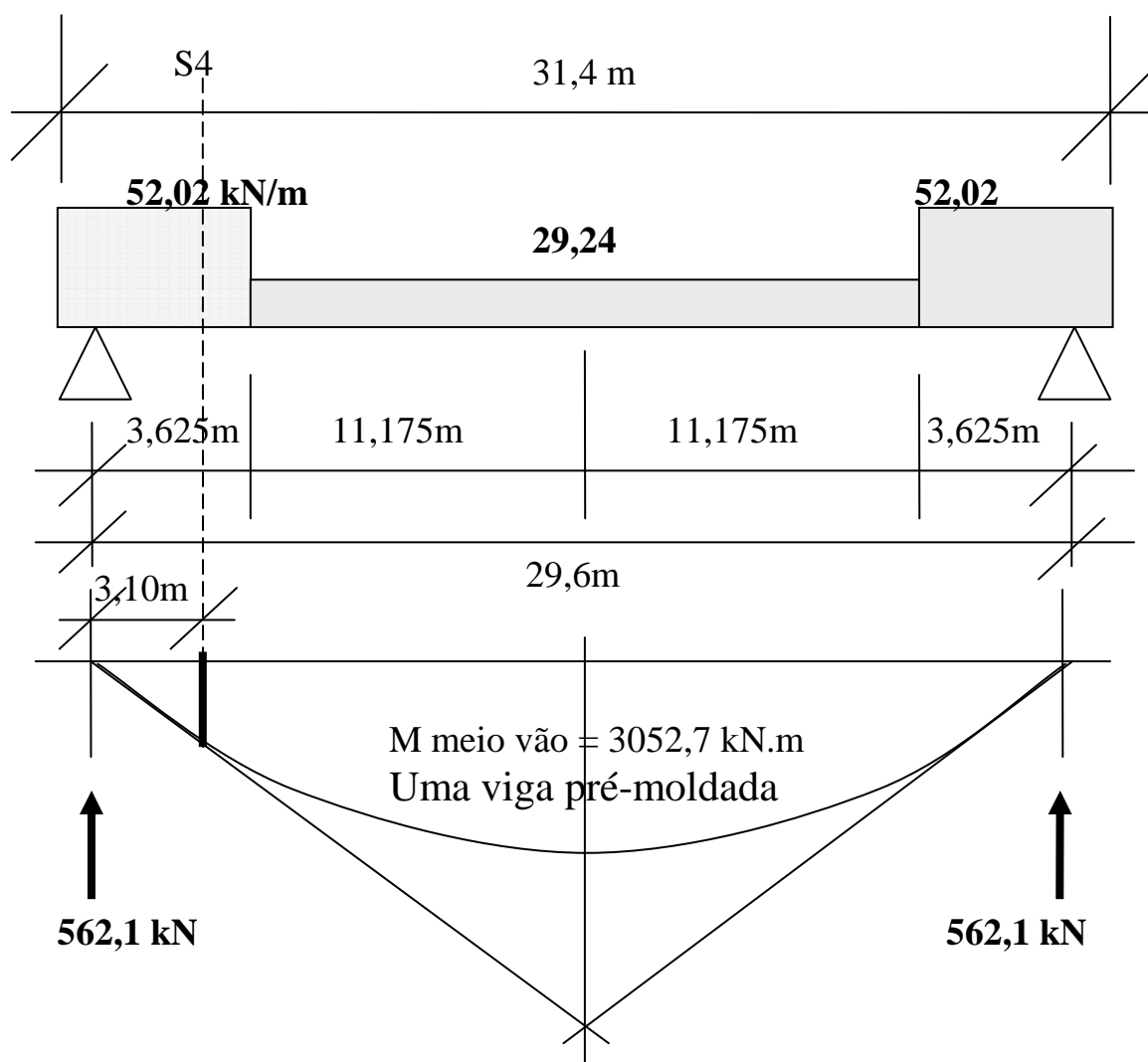

Seção 4

Força cortante = 354 kN

Momento fletor = 1326 kN.m



Laje + Transversinas

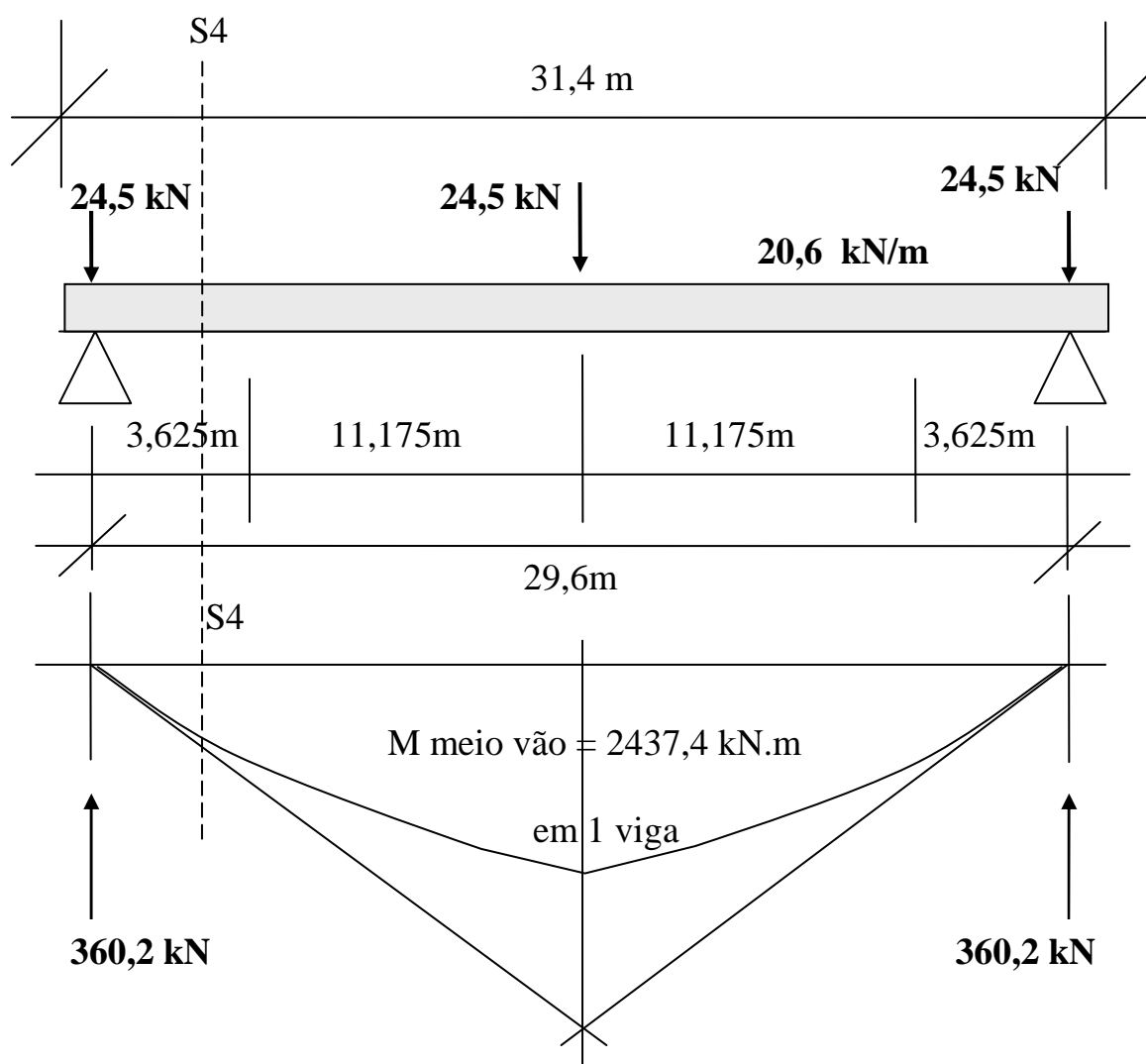

Seção S4

Força cortante = 253,3 kN

Momento fletor = 885,5 kN.m



Lastro Total + Trilhos

$$P = 41,7 \text{ kN/m}$$

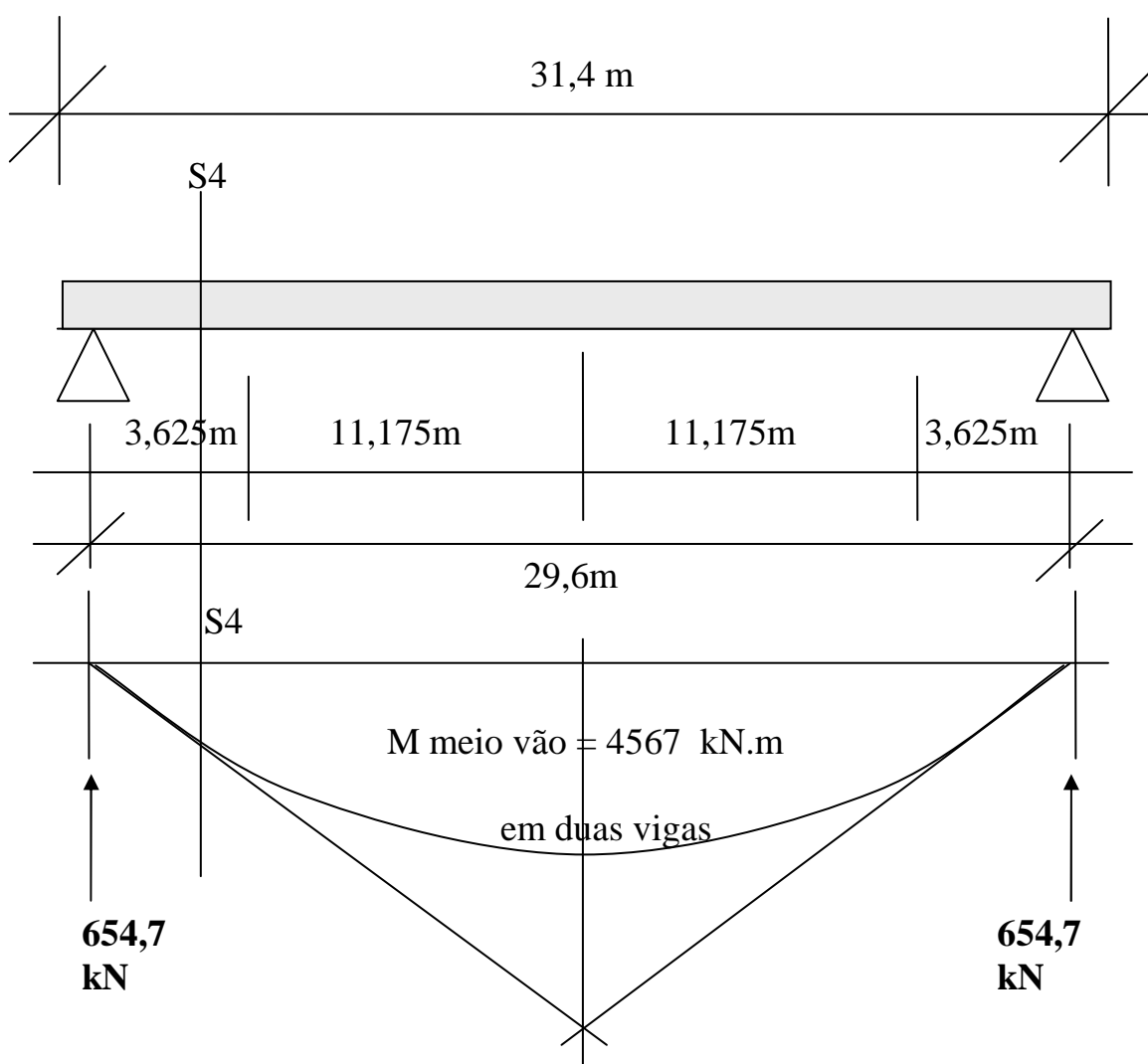

Seção S4 em 2 viga s

Força cortante = 525,4 kN

Momento fletor = 1696 kN.m



Resumo :

	Momento Fletor (kN.m)	Força cortante (kN)
Peso de 1 viga	1326	354
Laje + transversina	885,5	253,3
Lastro	1696/2vigas=848	525,4/2vigas=263
Carga Móvel	7931,9/2 vigas =3966	2571,1/2vigas=1286
Total	M = 7026 kN.m	V =2156 kN
Esforços majorados	Md = 1,4×M = 9836 kN.m	Vd = 1,4 V = 3018 kN

Cálculos iniciais:

$$f_{cd} = 28000 / 1.40 = 20000 \text{ kN/m}^2$$

$$f_{cd1}/f_{cd} = 0.85 [1 - 28/250] = 0.75$$

$$f_{yd} = 1500000 / 1.15 = 1304350 \text{ kN/m}^2 \text{ CP 175 RB}$$

$$f_{cwd} = f_{cd} = 20000 \text{ kN/m}^2$$

$$f_{cd2} = 0.60 [1 - 28 / 250] = 0.53$$

$$f_{ywd} = 500000 / 1.15 = 434782 \text{ kN/m}^2$$

$$1 \text{ cordoalha CP175 RB} = 95 \text{ kN}$$

Exemplo PONTE ENGEFER $f_{ck}=28\text{MPa}$ CP-175RB

20000 0.75 1304350 20000 0.53 434782

Secao S4

0.125 3.015 1.25

0 -1

45 90

6

1140 1.4 -14



1140 1.46 -12
1140 1.88 -11
1140 2.25 -8.5
1140 2.54 -6
1140 2.80 -5
1
carga total
0 3018 9836 0 0
0 0

Program Sheardes for shear design of beams according to the CEB-90 MC
Version 0.1, Modification 6 of 08/sept/1991

This program determines the compression force, the tensile force, the concrete web thickness and the amount of steel stirrups for flanged beams subjected to Axial force, Bending moment and Shear force.

This program was prepared by B. Ernani Diaz for the students of the Engineering School of the Federal University of Rio de Janeiro.

This program can be used for academic and research purposes.

INPUT em AZUL

Project Designation

secao S4 aco CP175 RB

Design stresses of the beam elements (item 6.2.2.2)

Flange_Concr, fcd1/fcd, Flange_Steel, Web_Concr, fcd2/fcwd, Stirr_Steel

fcd fcd1/fcd fyd fcwd fcd2/fcwd fywd

20000.0 0.7500 1304350.0 20000.0 0.5300 439782.0

Designation of the section

Secao S4

Z coordinates for the location of the flanges and beam axis

Upper_Fl. Lower_Fl. Beam_Axis

0.125 2.95 1.250

Angles [degrees] of the Upper Flange and Lower Flange

Upper_Flange Lower_Flange

0.00 -1.00



Angles in degrees of the concrete struts and stirrups in the web

Concrete_Struts Steel_Stirrups

45.00 90.00

Number of Prestressing Cables in the Web

6

Cable Design Force(items 1.4.3.2,1.6.2.4), Z-coordinate and Angle

Cable_Force(positive value) Z_Coord. Angle[degree]

1140.00 1.40 -14.00

1140.00 1.46 -12.00

1140.00 1.88 -11.00

1140.00 2.25 -8.00

1140.00 2.54 -6.00

1140.00 2.80 -5.00

Number of loadings

1

Loading Designation

carga total TB36

Design Internal Forces (multiplied by safety factors)

Axial_Force Shear_Force Bend_Moment Addit_Upper_Force Addit_Lower_Force

Nd Vd Md design value design value

0.00 3018.00 9836.00 0.00 0.00

Design Distributed Forces (multiplied by safety factors)

Up_Dist_Force Lo_Dist_Force

0.0 0.00

...



OUTPUT em vermelho

carga total TB36

Computed Forces and Design

Upper flange

Force	Necess. Area	Material
-4620.19	0.308013	concrete

área disponível em uma viga = $3,15\text{m} \times 0,20\text{m} = 0,63\text{m}^2 > 0,308\text{m}^2$

Lower flange

Force	Necess. Area	Material
- 204.39	0.013626 m ²	concrete

- 204.39 0.013626 m² concrete Não precisa de Cabos. Está comprimido.

Distributed forces in the web [force/length] and Design

Z_Coord	Strut_Forc	Stirr_Forc	Long_Forc	Shear_Forc	Web_Thickn	Steel_A/s
0.125	-1405.90	702.95	-702.95	702.95	0.13m	0.001598 m ² /m
1.510	-1381.99	702.95	-691.00	691.00	0.13m	0.001598 m ² /m
2.895	-1358.08	702.95	-679.04	679.04	0.13m	0.001598 m ² /m

Área necessária de estribo = 15,98 cm² / m.

Usar ferro 12,5mm cada 15cm = 16,4cm²/m

End of the Program



Formulação direta

Espessura da alma, compressão na biela.

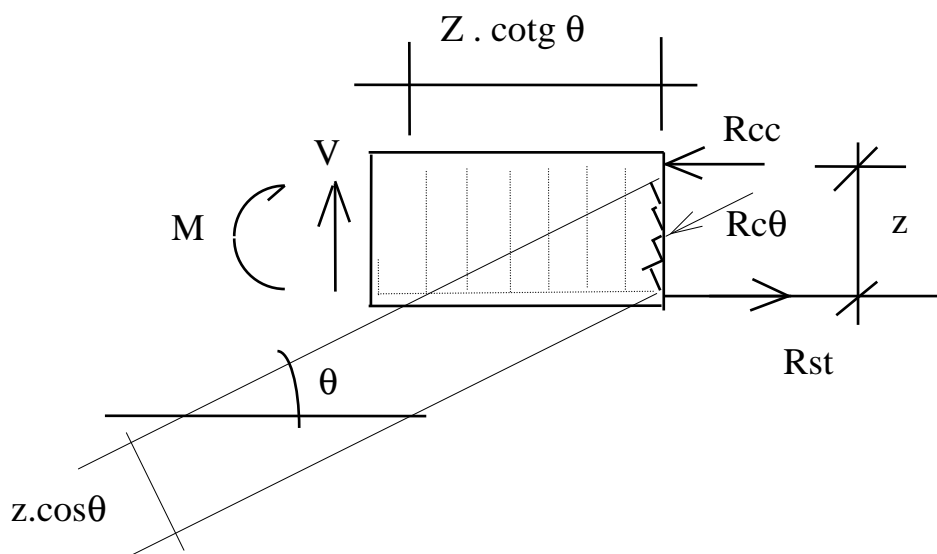
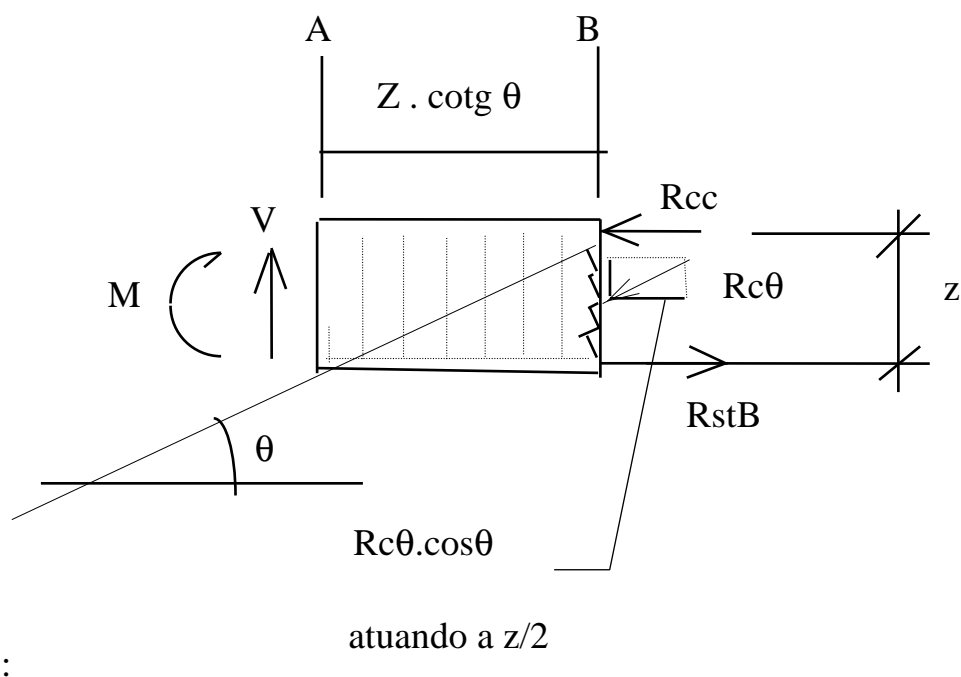



A resultante das tensões de compressão na biela vale :

$$R_{c\theta} = \sigma_{c\theta} \cdot b \cdot (z \cdot \cos \theta)$$

onde b = largura da viga

A componente vertical de $R_{c\theta}$ será igual à força cortante reduzida das forças nos cabos .

$$R_{c\theta} \cdot \sin \theta = \sigma_{c\theta} \cdot b \cdot (Z \cdot \cos \theta) \cdot \sin \theta = V \text{ reduzido} = V - \sum F \text{ cabos} \times \sin \alpha$$

$$\sigma_{c\theta} = (V \text{ red.} / b \cdot Z) \cdot (1 / \sin \theta \cdot \cos \theta) = 2 \tau \text{ red.} / \sin 2\theta$$

Logo a tensão nas bielas comprimidas diagonais vale :

$$\sigma_{c\theta} = \frac{2 \cdot \tau \text{ red.}}{\sin 2\theta}$$

Cabos :

Cabo	Força no cabo	z	α = inclinação do cabo (graus)	F cabo \times $\sin \alpha$ (kN)
C6	1140	1,40	-14	275,8
C5	1140	1,46	-12	237,0
C3	1140	1,88	-11	217,5
C1	1140	2,25	-8	158,7
C2	1140	2,54	-6	119,2
C4	1140	2,80	-5	99,3
				$\Sigma = 1107,5 \text{ kN}$



$$f_{cd2} = 0.60 [1 - 28 / 250] = 0.53$$

$$\sigma_{c\theta} = 0,53 \times 20000 \text{ (kN / m}^2\text{)} \leq \frac{2 \cdot \tau \cdot \text{red.}}{\text{sen}2\theta} = \frac{2 \times \left(\frac{V \text{ red.}}{b \times z} \right)}{\text{sen}2\theta} =$$

$$\sigma_{c\theta} \leq \frac{2 \times \left(\frac{3018 \text{ kN} - 1107,5 \text{ kN}}{b \times (2,895 \text{ m} - 0,125 \text{ m})} \right)}{\text{sen}(2 \times 45 \text{ graus})} = \frac{1379}{b} \text{ (kN / m}^2\text{)}$$

$$b_{\text{ necess\u00e1rio }} \geq 0,130 \text{ m}$$

A largura da viga deve ser a soma :

$$\mathbf{b \text{ real}} = b_{\text{ necess\u00e1rio }} + \text{di\u00e2metro da bainha} = 13 \text{ cm} + 7 \text{ cm} = 20 \text{ cm}$$

A largura m\u00ednima usada no projeto \u2713 25cm **OK**



Armadura de Flexão

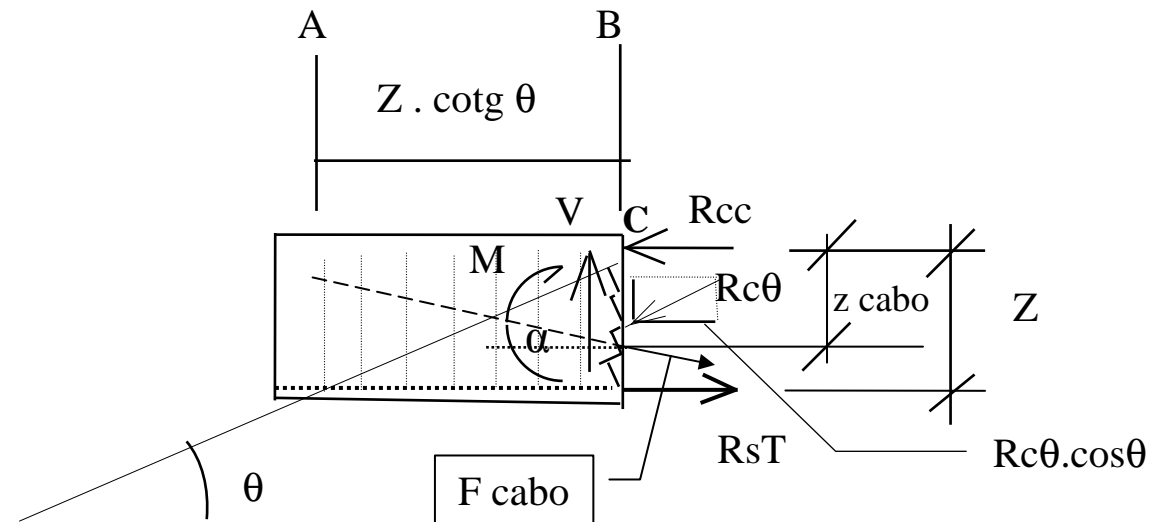

$R_c\theta$ atuando a $z/2$

Equilíbrio de momentos em torno do ponto C.

$$M + R_c\theta \times \cos\theta \times (Z/2) - R_{sT} \times Z - \sum (F_{cabo} \times \cos\alpha \times z_{cabo}) = 0$$

$$\text{Como } R_c\theta \times \sin\theta + \sum (F_{cabo} \times \sin\alpha) = V ;$$

$$R_c\theta = [V - \sum (F_{cabo} \times \sin\alpha)] / \sin\theta = V_{red.} / \sin\theta$$

$$[M - \sum (F_{cabo} \times \cos\alpha \times z_{cabo})] + [(V_{red.} / \sin\theta) \times \cos\theta] \times (Z/2) = R_{sT} \times Z$$

$$[M_{red,B} - \sum (F_{cabo} \times \cos\alpha \times z_{cabo})] + [V_{red,B} \times (Z/2) \times \cotg\theta] = R_{sT} \times Z$$

$$[M_{red,B}] + [V_{red,B} \times (Z/2) \times \cotg\theta] = R_{sT} \cdot Z$$

$$R_{st,B} = \frac{1}{Z} \left[M_{red,B} + V_{red,B} \times \frac{Z}{2} \times \cot\theta \right]$$



No exemplo da ponte da ENGEFER :

Cabo	Força no cabo F_{cabo} (kN)	Z a partir do topo (m)	A (graus)	$F_{cabo} \times \sin \alpha$ (kN)	$F_{cabo} \times \cos \alpha$ (kN)	$(F_{cabo} \times \cos \alpha) \times$ $\times (z_{topo} - 0,125m)$ (kN.m)
C6	1140	1,40	-14	275,8	1106,1	1410,3
C5	1140	1,64	-12	237,0	1115,1	1689,3
C3	1140	1,88	-11	217,5	1119,0	1963,8
C1	1140	2,25	-8	158,7	1128,9	2398,9
C2	1140	2,54	-6	119,2	1133,7	2737,9
C4	1140	2,80	-5	99,3	1135,7	3038,0
				$\Sigma = 1107,5$ kN		$\Sigma = 13238,2$ kN.m
C7 e C8	A determinar	2,95	-1			

Armadura de Flexão :

$$R_{st, B} = \frac{1}{Z} \times \left(M_{red, B} + V_{red, B} \times \frac{Z}{2} \times \cot \theta \right)$$

$$z = 3,10m - 0,125m - 0,15m = 2,825m$$

$$V_{red} = 3018 \text{ kN} - 1107,5 \text{ kN (cabos)} = 1910,5 \text{ kN}$$

$$M_{red} = 9836,00 \text{ kN.m} - 13238,2 \text{ kN.m (cabos)} = -3402 \text{ kN.m}$$

$$R_{st, B} = \frac{1}{z} \left[M_{red, B} + V_{red, B} \times \frac{z}{2} \times \cot \theta \right] =$$

$$R_{st, B} = \frac{1}{2,77m} \times \left[-3402 + 1910,5 \text{ kN} \times \left(\frac{2,825m}{2} \right) \times \cot 45 \text{ graus} \right] =$$

$$R_{st, B} = \frac{1}{2,77m} \times [-3402 \text{ kN.m} + 2698,6 \text{ kN.m}] = -253,94 \text{ kN (compressão)}$$

Não precisa de cabo no bordo inferior. A força na armadura deu compressão.

$$A_{aço existente} = 2 \text{ cabos de } 12 \text{ cordoalhas } 12,5mm = 2 \times 12 \times 1,0cm^2 = 24cm^2 \quad OK$$



Compressão na mesa superior :

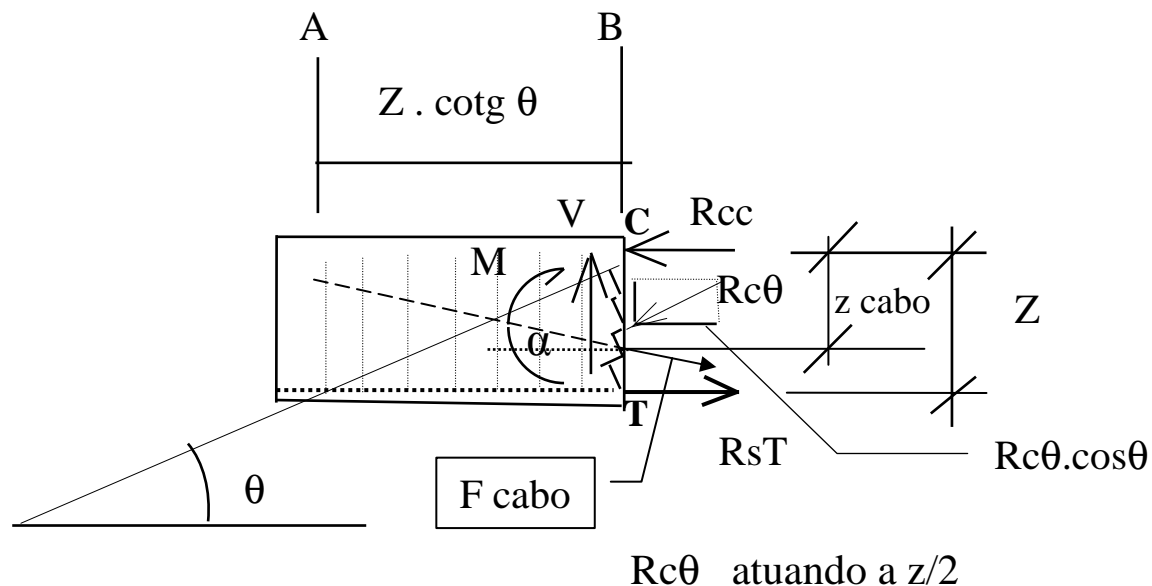

Equilíbrio dos momentos em torno do ponto T.

$$\Sigma M_T = 0$$

$$M + \Sigma \left[F_{\text{cabo}} \times \cos \alpha \times (Z - z_{\text{cabo}}) \right] = R_{cc} \times Z + R_{c\theta} \times \cos \theta \times \frac{Z}{2}$$

$$R_{cc} = \frac{M + \Sigma \left[F_{\text{cabo}} \times \cos \alpha \times (Z - z_{\text{cabo}}) \right] - R_{c\theta} \times \cos \theta \times \frac{Z}{2}}{Z}$$

como

$$R_{c\theta} \times \sin \theta = V - \Sigma (F_{\text{cabo}} \times \sin \alpha)$$

$$R_{cc} = \frac{M + \Sigma \left[F_{\text{cabo}} \times \cos \alpha \times (Z - z_{\text{cabo}}) \right] - \left[\frac{V - \Sigma (F_{\text{cabo}} \times \sin \alpha)}{\sin \theta} \right] \times \cos \theta \times \frac{Z}{2}}{Z}$$

$$R_{cc} = \frac{M + \Sigma \left[F_{\text{cabo}} \times \cos \alpha \times (Z - z_{\text{cabo}}) \right] - \left[V - \Sigma (F_{\text{cabo}} \times \sin \alpha) \right] \times \cot \theta \times \frac{Z}{2}}{Z}$$



Cabo	F _{cabo} (kN)	Z a partir do topo (m)	z a partir do topo (m)	Z-z.cabo	α (graus)	F _{cabo} × senα (kN)	F _{cabo} × cosα (kN)	F _{cabo} × cosα × (Z-z.cabo) (kN.m)
C6	1140	2.95	1,40	1,55	-14	275,8	1106,1	1714,4
C5	1140	2.95	1,64	1.31	-12	237,0	1115,1	1460,8
C3	1140	2.95	1,88	1.07	-11	217,5	1119,0	1197,3
C1	1140	2.95	2,25	0.7	-8	158,7	1128,9	790,2
C2	1140	2.95	2,54	0.41	-6	119,2	1133,7	464,8
C4	1140	2.95	2,80	0.15	-5	99,3	1135,7	170,4
C7 e C8	determinar	2.95	2,95	0	-1	Σ = 1107,5 kN	Σ = 6738,5 kN	Σ = 5797,9 kN.m

Md = 9836 kN.m Vd=3018kN

$$R_{cc} = \frac{M + \Sigma [F_{cabo} \times \cos \alpha \times (Z - z_{cabo})] - [V - \Sigma (F_{cabo} \times \sin \alpha)] \times \cot \theta \times \frac{Z}{2}}{Z}$$

...

$$R_{cc} = \frac{9836 \text{ kN.m} + 5797,9 \text{ kN.m} - (3018 - 1107,5) \text{ kN} \times \cot 45^\circ \times \frac{(2,95 \text{ m} - 0,125 \text{ m})}{2}}{(2,95 \text{ m} - 0,125 \text{ m})} =$$

$$R_{cc}(\text{compressão}) = \frac{(9836 + 5797,9 - 2698,6) \text{ kN.m}}{2,825 \text{ m}} = 4579 \text{ kN}(\text{compressão})$$

Observação : R_{cc} segundo o programa Sheardes = 4620 kN



Compressão na mesa superior (outro modo de calcular) :

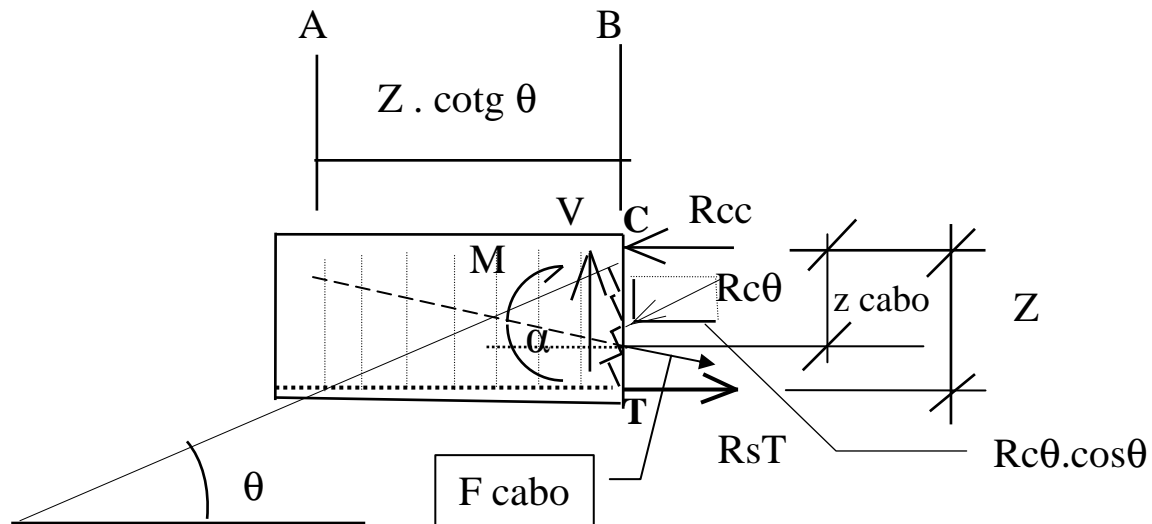

$R_{c\theta}$ atuando a $z/2$

Equilíbrio de força normais (horizontais) :

$$R_{sT} + \sum (F_{cabo} \times \cos \alpha) - R_{c\theta} \times \cos \theta - R_{cc} = 0$$

$$R_{cc} = R_{sT} + \sum (F_{cabo} \times \cos \alpha) - R_{c\theta} \times \cos \theta$$

Como :

$$R_{c\theta} \times \sin \theta = V - \sum (F_{cabo} \times \sin \alpha)$$

$$R_{c\theta} \times \cos \theta = [V - \sum (F_{cabo} \times \sin \alpha)] \times (\cos \theta / \sin \theta)$$

$$R_{c\theta} \times \cos \theta = [V - \sum (F_{cabo} \times \sin \alpha)] \times \cot \theta$$

$$R_{cc} = R_{sT} + \sum (F_{cabo} \times \cos \alpha) - [V - \sum (F_{cabo} \times \sin \alpha)] \times \cot \theta$$

$$R_{cc} = R_{sT} - V \times \cot \theta + \sum (F_{cabo} \times \cos \alpha) + [\sum (F_{cabo} \times \sin \alpha)] \times \cot \theta$$

$$R_{cc} \text{ (compressão)} = (-253,94) - 3018 \times \cot 45^\circ + 6738 + 1107,5 \times \cot 45^\circ = 4574 \text{ kN}$$

Resumo:

Programa Sheardes $R_{cc} = 4579 \text{ kN}$

Equilíbrio de momentos : $R_{cc} = 4620 \text{ kN}$

Equilíbrio de forças horizontais : $R_{cc} = 4574 \text{ kN}$

Resultados praticamente iguais, a menos da precisão dos cálculos.



Armadura de estribos :

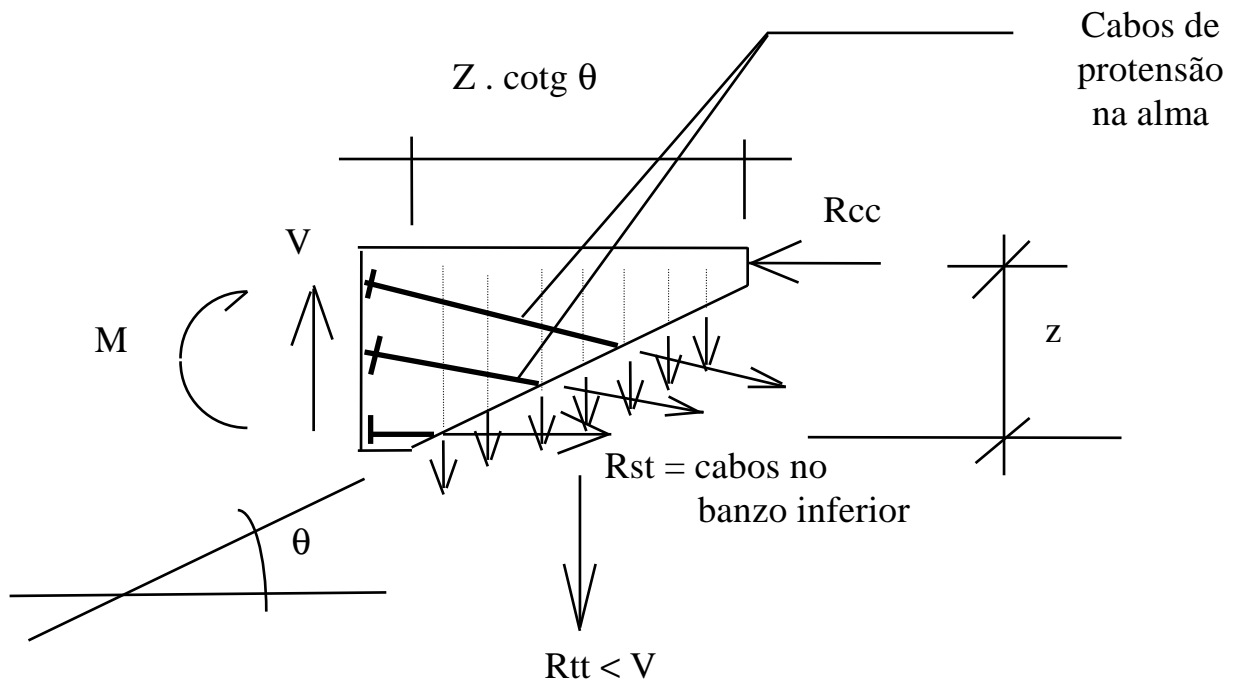

$$V = R_{tt} + \Sigma F \text{ cabos} \times \text{sen}\alpha$$

$$R_{tt} = V - \Sigma F \text{ cabos} \times \text{sen}\alpha = 3018 \text{ kN} - (\approx 1107,5 \text{ kN}) \approx 1910,5 \text{ kN}$$

$$\frac{A \text{ estribo}}{\text{metro}} = \frac{R_{tt}}{(z \times \cot\theta) \times f_{yd}} = \frac{V - \Sigma F \text{ cabos} \times \text{sen}\alpha}{(z \times \cot\theta) \times f_{yd}} =$$

$$\frac{A \text{ estribo}}{\text{metro}} = \frac{3018 \text{ kN} - 1107 \text{ kN}}{(2,895 \text{ m} - 0,125 \text{ m}) \times \cot 45 \times \frac{50 \text{ kN/cm}^2}{1,15}} = 15,98 \text{ cm}^2/\text{m}$$

Observação : $\frac{A \text{ estribo}}{\text{metro}}$, segundo programa Sheardes = 15,98 cm²/m

Estribos (2 pernas) de 12,5mm cada 15cm = 16,4 cm² /m